

Voltage Regulator Module User's Guide

Rev 1.0



Cross The Road Electronics

www.crosstheroadelectronics.com

Table of Contents

1. Voltage Regulation Module at a Glance	3
1.1. Connection Specifications	5
1.2. Electrical Specifications	5
1.3. Mechanical Specifications	6
2. Installing a VRM.....	7
2.1. Weidmuller Connectors	8
3. Typical Performance Characteristics	9
4. Revision History	11

1. Voltage Regulation Module at a Glance

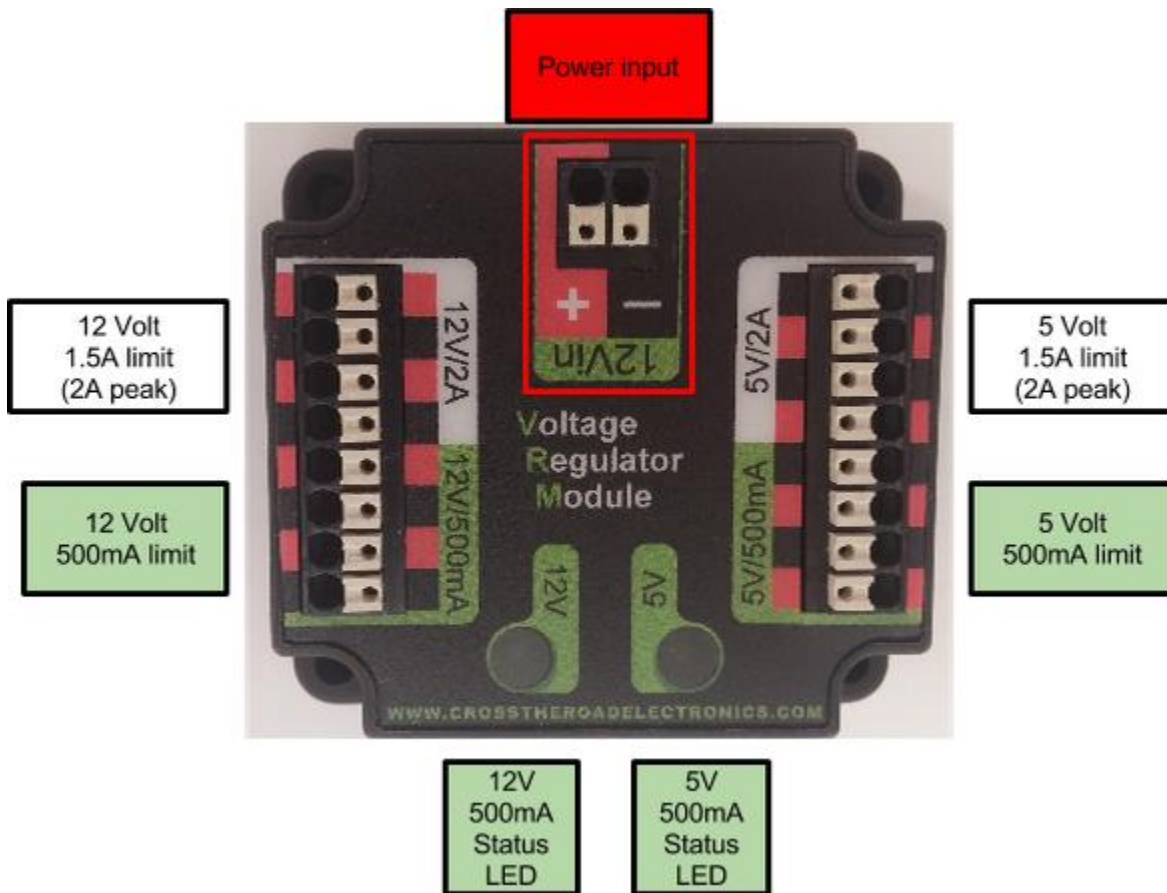

- 5V/500mA Status LED
 - **ON** when 5V channels are powered
 - **OFF** when breaker has tripped
- 12V/500mA Status LED
 - **ON** when 12V channels are powered
 - **OFF** when breaker has tripped

LEDs NOT affected when 2A channels are limited

Device Description

The VRM is a DC to DC convertor that is capable of both boost and buck voltage regulation. The device features two independent SEPIC (Single Ended Primary-inductor Converter) regulators allowing the **input** voltage to be above or below the desired **output** voltage. There are two regulators (one 5V and one 12V) each with two current limiting PTC's (500mA and 2A). Reverse polarity protection is included.

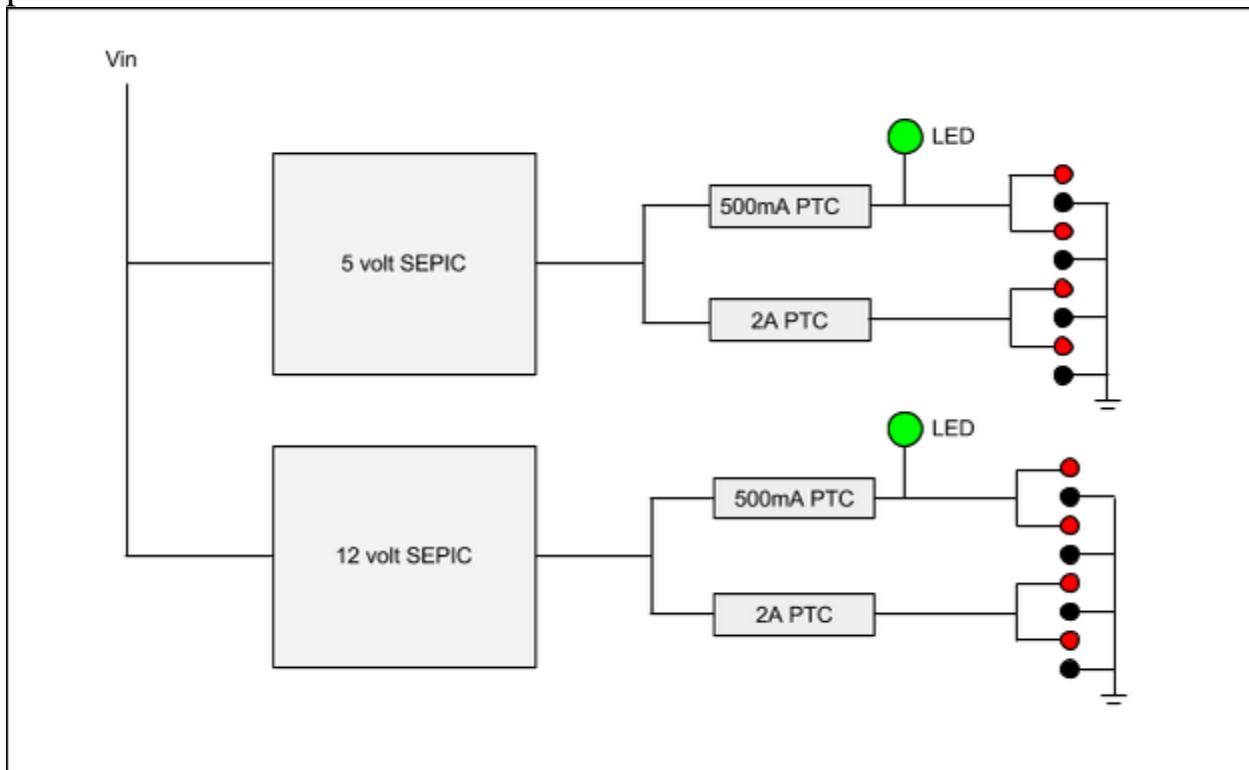

1.1. Connection Specifications

- **Power, 12V/500mA, 12V/2A, 5V/500mA, 5V/2A**
 - All connections are Weidmuller Connectors
 - **Max Size:** 16 AWG
 - **Min Size:** 24 AWG

See [Section 2.1. Weidmuller Connectors](#) for wire insert instructions.

1.2. Electrical Specifications

Rating	Min	Typical	Max	Unit
Input/Battery Voltage (Vin)	5	12	16	V
Functional Min Input Voltage Vin _{MIN}		5		V
Functional Max Input Voltage Vin _{MAX}		16		
Absolute Max Input Voltage ⁽¹⁾			20	V
Output Voltage (no load, Vin = 12.5)				
12V/500mA Rail	11.93	12.197	12.49	V
12V/2A Rail	11.93	12.197	12.49	V
5V/500mA Rail	5.0	5.13	5.29	V
5V/2A Rail	5.0	5.13	5.29	V
Output Impedance				
12V/500mA Rail	0.15856		1.00942	Ω
12V/2A Rail	0.02356		0.10942	Ω
5V/500mA Rail	0.15818		1.009	Ω
5V/2A Rail	0.02318		0.109	Ω
Peak Current				
12V/500mA and 5V/500mA			500	mA
12V/2A and 5V/2A			2000	mA
Continuous Current				
12V/500mA and 5V/500mA			500	mA
12V/2A and 5V/2A			1500	mA

Note 1: Stresses above those listed under "Absolute Maximum Ratings" may cause permanent damage to the device. This is a stress rating only and functional operation of the device at those or any other conditions above those indicated in the operation listings of this specification is not implied. Exposure to maximum rating conditions for extended periods may affect device reliability.

1.3. Mechanical Specifications

Length	2.220 in.
Width	2.030 in.
Height	0.784 in.
Weight	1.8 oz.

2. Installing a VRM

Powering VRM

- Disconnect PDP from Battery before adding or modifying connections
- Connect VRM to 20A Fused Power Supply on PDP.

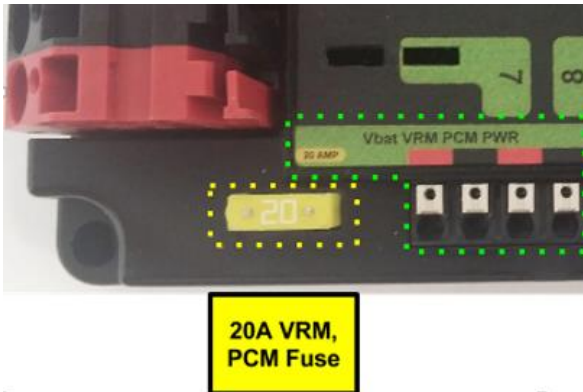

Either of the left two pairs of Weidmuller (red/black) can be used for VRM power. Red is for positive, black is for ground.



- Connect PDP to Battery

12V Output Voltage Channels

- 500mA Channel
 - Connect devices requiring constant 12V power supply that draw less than 500mA
- 2A (peak) Channel
 - May be used to devices with high current requirements

5V Output Voltage Channels

- 500mA Limit
 - Connect devices requiring constant 5V power supply that draw less than 500mA
- 2A (peak) Limit
 - Used to power radio

Limitations

- Current draw must not exceed 500mA on 500mA-channel.
- Continuous current draw must not exceed 1.5A on 2A-channel.
- Peak current draw must not exceed 2A on 2A-channel.
- Input voltage **must** be between V_{in-MIN} and V_{in-MAX} to maintain constant Output Voltage.

2.1. Weidmuller Connectors

Wire Insertion

- Disconnect PDP from Battery before adding or modifying connections
- Strip wire back **~0.375" (3/8")**
- Press and hold down connector button. Though this isn't necessary, it ensures the stripped wire does not deform and split into "whiskers" after excessive use. A small screwdriver can be used to easily hold down the connector button.
- Insert wire into connector opening
- Release connector button
- Pull wire to ensure wire is locked in connector
- Confirm wire strands are not extruded

Wire Inspection

- Verify that there are no "whiskers" outside of the connector that may cause a short.
- Verify that the stripped portion of the wire is not excessive enough to cause a short.
- Tug on the wire and verify wire does not pull out. If it does then recheck gauge and/or strip the wire back further.

Wire Removal

- Press and hold down connector button immediately above connector opening
- Pull wire to remove from connector

Limitations

- Wire should **not be frayed** upon insertion. Extruded wire may short to adjacent channels.
- Wire should be **no larger than 16 AWG**, larger gauges will not properly fit in connector
- Wire should be **no smaller than 24 AWG**, smaller gauges will not lock in connector

3. Typical Performance Characteristics

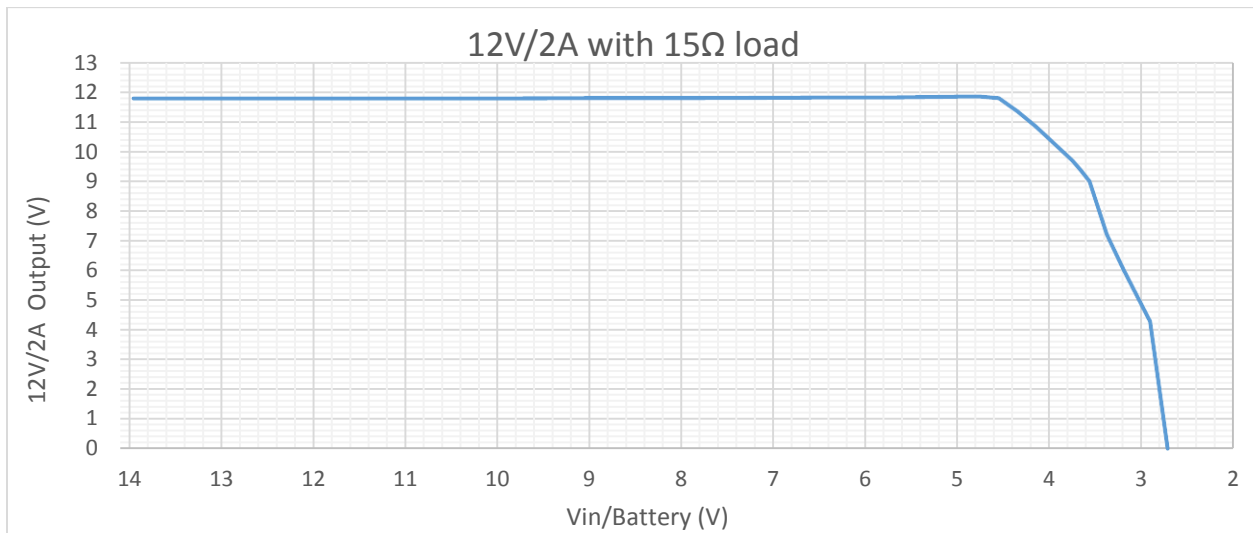
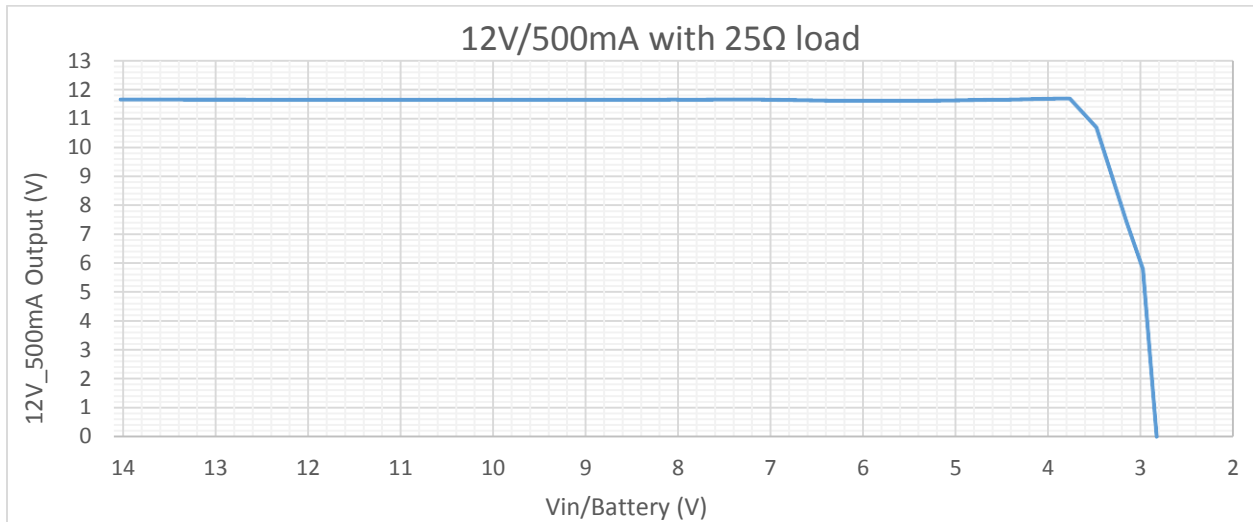

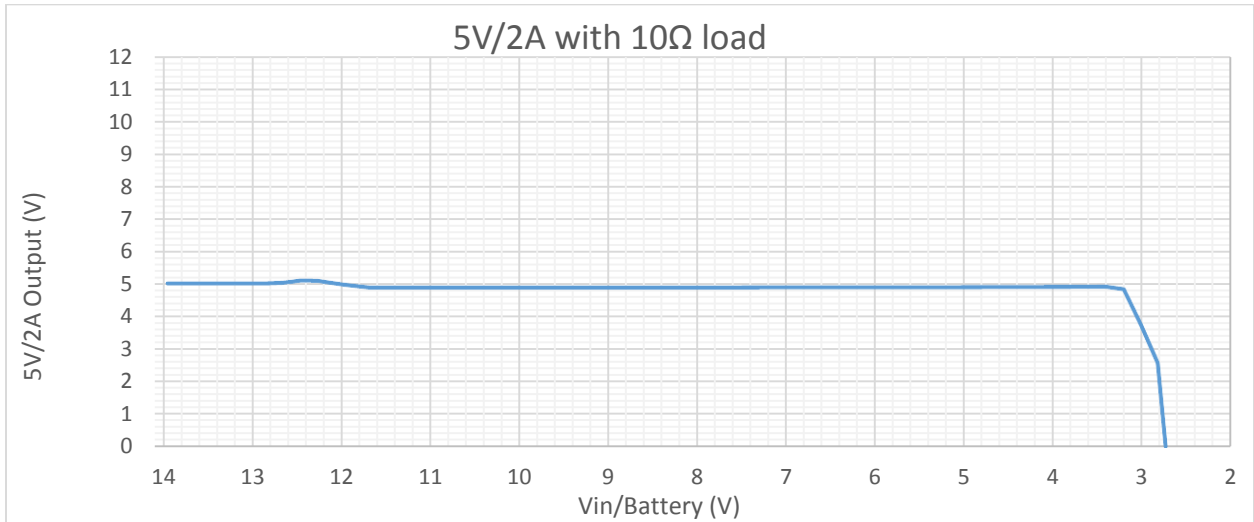
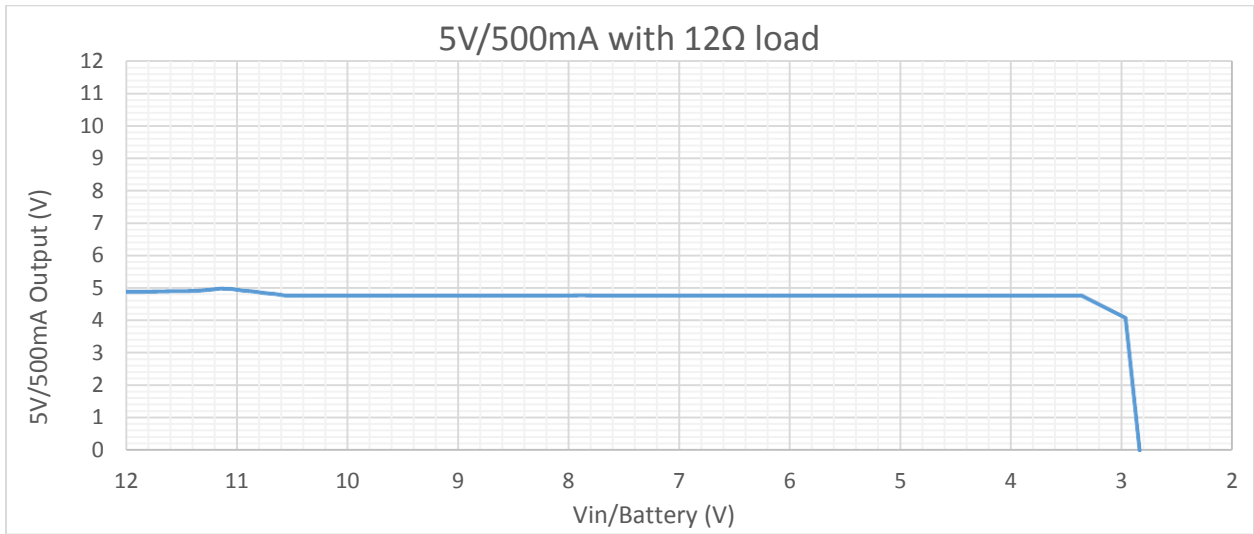

4. Revision History

Rev	Date	Description
1.0	30-Dec-14	Initial Creation